

WHITE PAPER

Lenses in surveillance

January 2025

Summary

The lens controls the camera's field of view and the amount of light that reaches the camera sensor. It also focuses the image. A fixed lens, a varifocal lens, and a zoom lens offer different degrees of flexibility, depth of field, and remote adjustment capabilities.

The field of view describes the angle that the camera can capture. It is determined by the focal length of the lens and the size of the image sensor. The longer the focal length, the narrower the field of view. A wide angle lens, a normal view lens, and a telephoto lens provide different fields of view that you can match with your use case.

The iris of a lens works in similar ways to the iris of the human eye. It controls the amount of light that passes through so that the camera image is correctly exposed. It can also be used to optimize image quality aspects, such as resolution, contrast, and depth of field. In environments with controlled light levels you can use a fixed iris lens, but in more challenging light conditions you need a DC-iris lens or P-Iris lens, for which the camera can modify and optimize the iris.

Lenses are also categorized based on their different mount standards. Many surveillance cameras come with block lenses, which use motors to optimize the image quality but can't be exchanged. M12, or S-mount, lenses are small lenses typically used in modular cameras, body worn cameras, and intercoms, and they are sometimes exchangeable. C-mount or CS-mount lenses are exchangeable lenses used in box cameras. An i-CS lens is a CS-mount lens with built-in motors for adjusting zoom and focus remotely.

Axis provides tools like Lens calculator, AXIS Site Designer, and Accessory selector to help you choose a lens for your camera. They are accessible from www.axis.com/support/tools

Table of Contents

1	Introduction	4
2	Functions of a lens	4
3	Lens types	5
4	Focal length	5
5	Field of view	6
6	F-number	7
7	Iris types	8
8	Depth of field	9
9	Matching lens and sensor	10
10	Lens types in surveillance	11
11	Lens marking	12
12	Tools	13
	12.1 Lens calculator	13
	12.2 AXIS Site Designer	14
	12.3 Accessory selector	15

1 Introduction

A lens is a transparent optical device that concentrates light on a camera's image sensor to create clear and focused images. In video surveillance, clear images are necessary for effective scene monitoring, and the camera lens is a critical component. With numerous lens options available, factors such as field of view, focal length, iris type, and sensor compatibility should be carefully considered.

This white paper explains the concept of the lens in video surveillance; what it does, the main types of lenses, and the factors to consider when selecting and configuring lenses for optimal image quality.



2 Functions of a lens

A lens (or an assembly of lens elements) on a camera performs several functions. These include:

- defining the field of view. This determines how much of a scene can be seen in the image.
- preserving the details of the scene by matching the lens resolution to the sensor resolution.
- controlling the amount of light reaching the image sensor so that the image is correctly exposed.
- focusing the image. This is done by adjusting the lens elements within the lens assembly, or by changing the distance between the lens assembly and the image sensor.

3 Lens types

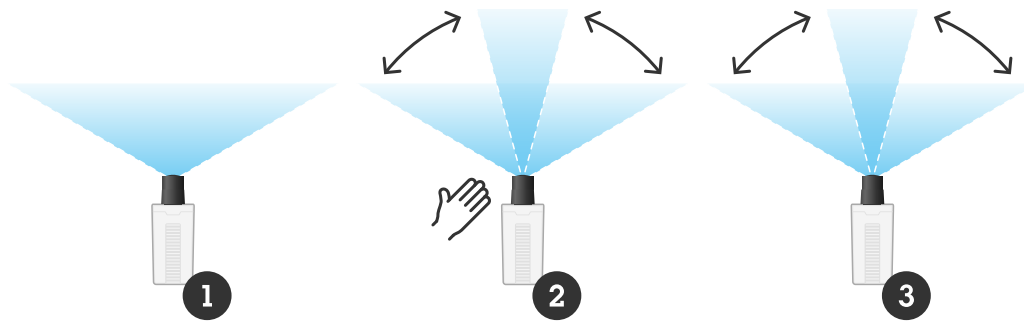

Camera with a fixed lens (1), a varifocal lens (2), and a zoom lens (3).

Depending on the use, there are different types of lenses to choose from:

- **Fixed focal length lens.** Also called fixed lens. The focal length is fixed and provides a single field of view.
- **Varifocal lens.** Offers a variable focal length, and thus different fields of view. The field of view can be adjusted on the lens or through the camera's web interface. Adjusting the focal length in a varifocal lens also requires the lens to be refocused.
- **Zoom lens.** Is like a varifocal lens in that it offers adjustable field of view, but here there is no need to refocus if the field of view is changed. Focus is maintained when changing focal length. This lens type is very uncommon in the security industry, but the function can be mimicked by motorized lenses.

4 Focal length

The focal length of a lens is a measure of how strongly the lens bends light. A lens with a short focal length bends light more. Focal length is normally measured in mm.

Note that the focal length does not correspond to the length of the physical lens, and there is no easy way to measure the focal length based on the lens itself.

For a lens assembly, the focal length (f) is defined as the distance between the image plane where the sensor is positioned (F) and an imaginary plane (H) where parallel incoming light rays seem to bend to focus on the sensor. This imaginary plane is called the principal plane.

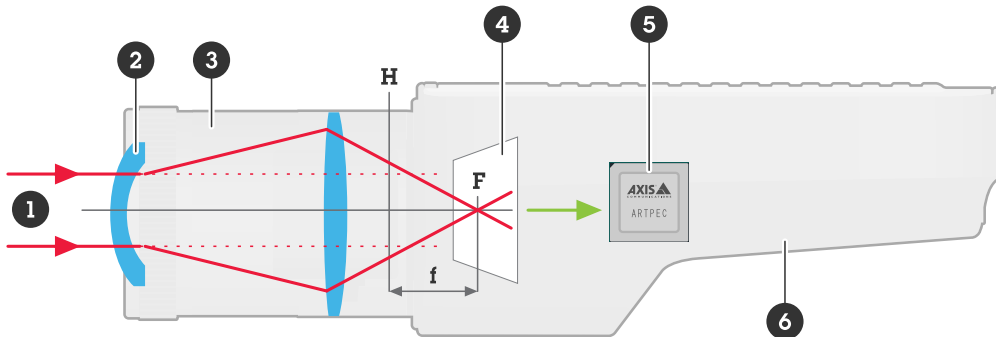

A lens mounted on a camera. The focal length (f) is defined as the distance between the image plane (F) where the sensor is positioned and the principal plane (H) where parallel incoming light rays seem to bend to focus on the sensor.

- 1 Incoming light
- 2 Lens element
- 3 Lens
- 4 Image sensor
- 5 Image processor
- 6 Camera housing

5 Field of view

The field of view describes the angle that the camera can capture. It is determined by the focal length of the lens and the size of the image sensor. The longer the focal length, the narrower the field of view. Field of view is sometimes labeled HFoV, VFoV, or DFoV, representing the horizontal, vertical, or diagonal field of view.

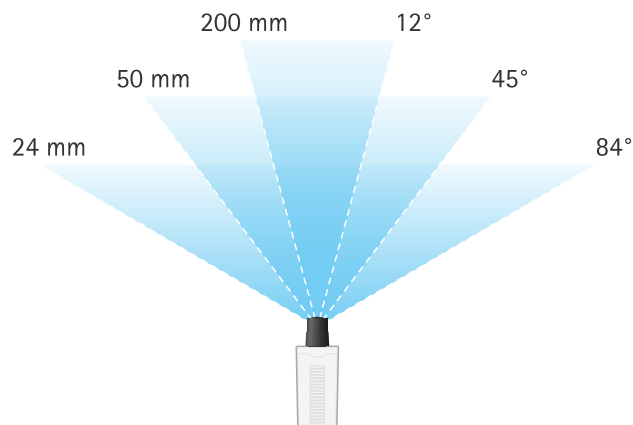

A larger focal length (in mm) provides a narrower field of view (in degrees).

A lens can be classified in one of three categories depending on which angles the lens can reproduce.

- **Wide angle lens.** Gives a much larger field of view than what is normal for the human eye. Generally also provides a large depth of field.
- **Normal view lens.** Gives a similar field of view as the human eye's central field of view.
- **Telephoto lens.** Gives a narrower field of view and provides a magnifying effect compared to human vision. Can sometimes result in a small depth of field.

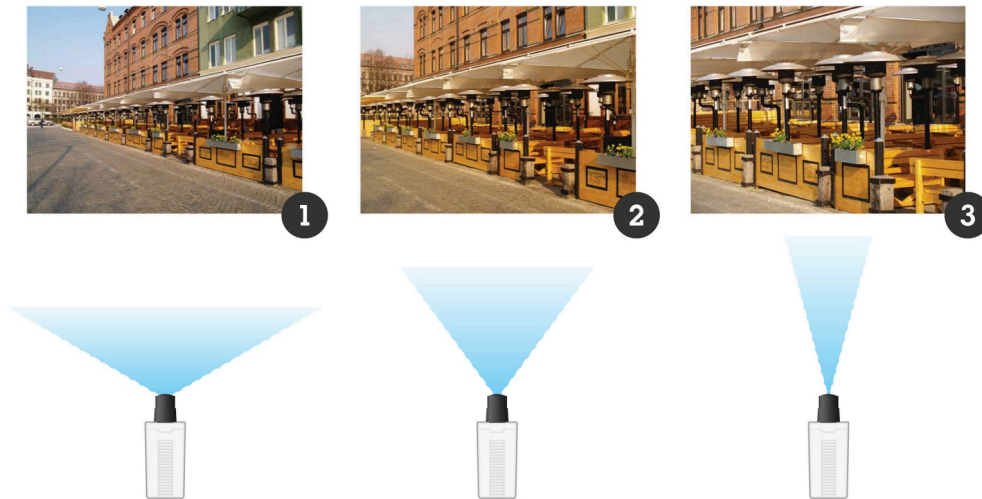

Field of view with wide angle lens (1), normal view lens (2), and telephoto lens (3).

6 F-number

The light gathering ability of a camera is specified by the f-number (also known as the f-stop) of the lens. The f-number defines how much light can pass through the lens and reach the image sensor. It is the ratio of the lens's focal length to the diameter of the lens's entrance pupil.

The smaller the f-number, the better the light gathering ability, that is, more light can pass to the image sensor. In low-light situations, a lower f-number generally produces better image quality, while a higher f-number increases the depth of field. A lens with a low f-number is normally more expensive than a lens with a higher f-number.

In some lenses the size of the aperture can be changed. This is done by the iris, which can be manual or controlled by the camera. When using a varifocal or zoom lens, the f-number changes when the focal length is changed. The longer the focal length, the higher the f-number. The f-number that is printed on the lens is normally valid only for the wide setting.



The light gathering ability of a camera is higher when the f-number is lower.

The entrance pupil is the optical image of the iris or aperture, as seen through the front (object side) of the lens system. If there was no lens in front of the aperture (as in a pinhole camera) the entrance pupil's

location and size would be identical to those of the iris. The entrance pupil is the area that collects light, and it can be smaller or larger than the physical size of the iris, depending on type of lens.

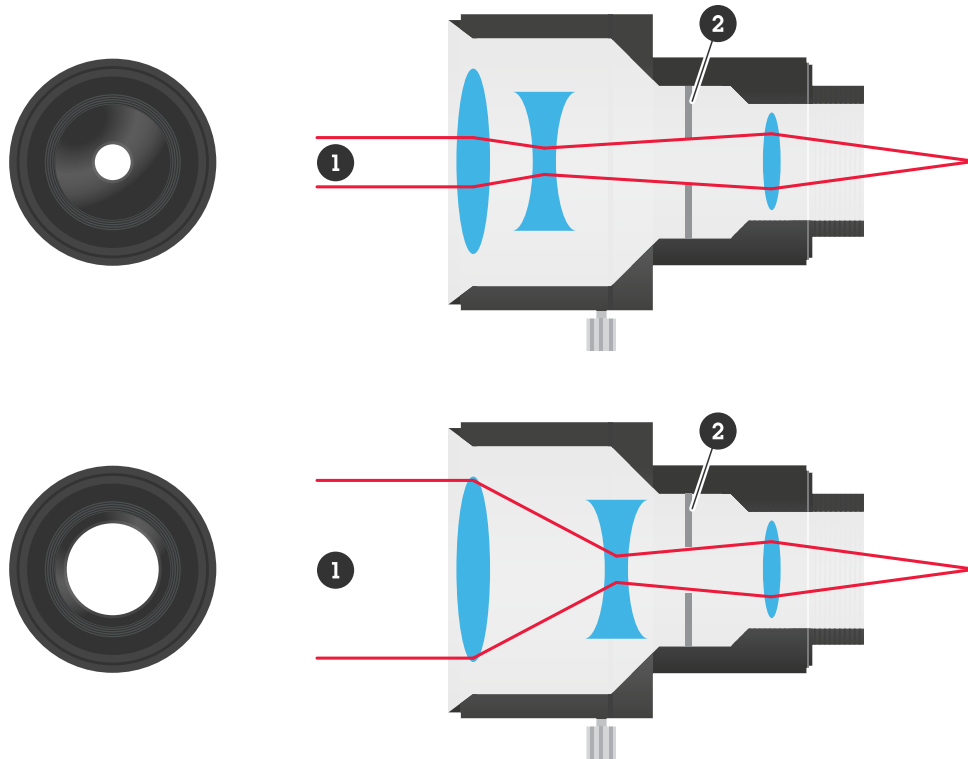

In a wide angle lens (top) the entrance pupil (1) is normally smaller than the physical iris (2). In a telephoto lens (bottom) the entrance pupil (1) is normally larger than the physical iris (2).

- 1 Entrance pupil
- 2 Iris

7 Iris types

The iris of a lens works in similar ways to the iris of the human eye. It controls the amount of light that passes through so that the camera image is correctly exposed. It can also be used to optimize image quality aspects, such as resolution, contrast, and depth of field.

Three types of iris are common in the security industry:

- In a **fixed iris** lens the size of the iris opening cannot be changed. This is used by the M12 (S-mount) lens. Lenses with this type of iris are mostly used in environments with controlled light levels, typically indoors.
- In a **DC-iris** lens the camera can automatically change the size of the iris opening in response to the light level and thereby controls the amount of light that reaches the image sensor. Lenses with this type of iris can be used in environments with more challenging light conditions, typically outdoors.

- In a P-Iris lens the camera can control the size of the iris opening much more precisely than with a DC-iris lens. The camera can not only optimize the amount of light reaching the image sensor but also adjust for better sharpness, contrast, and a more suitable depth of field.

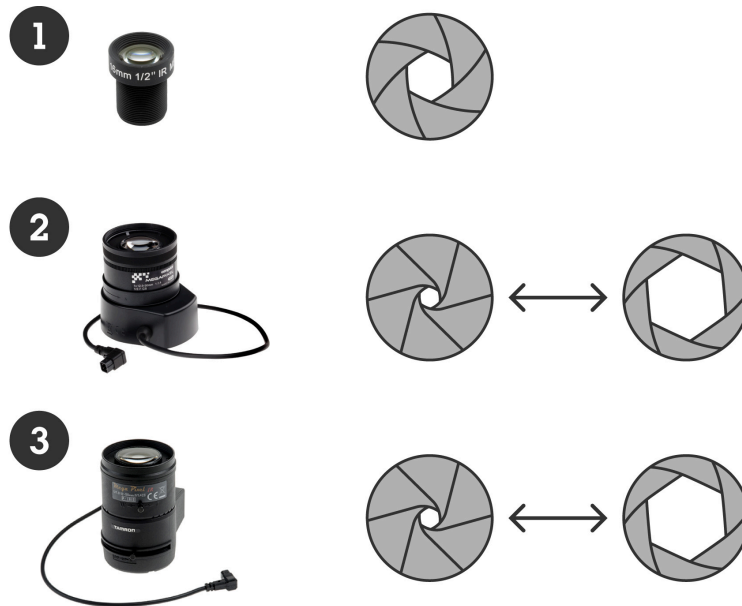

Iris types common in the security industry: fixed (1), DC-iris (2), P-Iris (3).

8 Depth of field

Depth of field refers to the distance between the closest and farthest objects that appear sharp simultaneously. This is important in applications such as the monitoring of a parking lot, where you may need to read license plates at 20, 30, and 50 meters (60, 90, and 150 feet) distance.

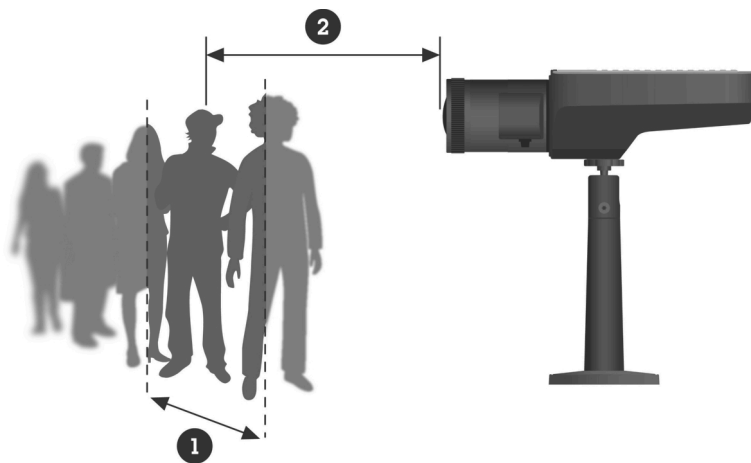

The depth of field (1) and the focal distance (2), which is the distance from the camera to its focal point. Having a larger depth of field means that objects appear sharp at a longer range around the focal point.

Depth of field is affected by four factors: focal length, f-number, distance between the camera and the subject, and how the image is viewed. The part about how the image is viewed relates to aspects like the pixel size, the distance between the monitor and the observer, the observer's eyesight, and so on.

A longer focal length, a lower f-number, a shorter distance between the camera and the subject, and a shorter distance between the monitor and the observer will all decrease the depth of field.



Left: photo with small depth of field – only the pens in the front are in focus. Right: photo with larger depth of field – all the pens are in acceptably sharp focus.

9 Matching lens and sensor

When you change lenses on a camera, it is important to match the lens to the camera's image sensor. If the lens is intended for a smaller sensor than the one in the camera, the image will have black corners. If the lens is intended for a larger sensor than the one in the camera, the field of view will be smaller than the lens's capability, because part of the information outside the image sensor will be lost. This situation creates a telephoto effect as it makes everything look zoomed in.



The effect of different lenses on a 1/1.8" sensor.

Right: a 1/2.7" lens is too small for the sensor and the image has black corners.

Center: a 1/1.8" lens matches the sensor size.

Left: a 1/1.2" lens is too large for the sensor and the information outside the image sensor will be lost.

10 Lens types in surveillance



A block lens uses motors to adjust the focus and zoom remotely as well as providing some possibilities for an optimized image quality. It is commonly used in PTZ, dome, and bullet cameras. This type of lens is built into the camera and cannot be exchanged.



An M12 lens usually has a fixed focal length and no iris control. Because of its small form factor it is used in modular cameras, some dome cameras, body worn cameras, and intercoms. In some cameras this lens is exchangeable. This lens is also known as S-mount lens.



A C or CS lens has a specific mounting thread, making it easy to exchange. This type of lens is used in box cameras. It exists in a variety of varifocal lengths with DC or P-Iris control. This lens offers great flexibility and is suitable for various surveillance applications.



An i-CS lens has the same thread as a C/CS lens, but has extra intelligence due to built-in motors for adjusting zoom and focus remotely. It offers similar benefits as the block lens, but it is exchangeable. It is compatible with box cameras that have i-CS support.

The mount standards C-mount and CS-mount are used for lenses that can be exchanged. Both standards are compatible with Axis box cameras.

C-mount and CS-mount look identical. They both have a 1-inch thread and a pitch of 32 threads per inch (TPI). CS-mount, which is more common than C-mount, is an update to the C-mount standard.

The only difference between C-mount and CS-mount is the flange focal distance (FFD), that is, the distance from the mounting flange to the camera's image sensor when the lens is mounted on the camera.

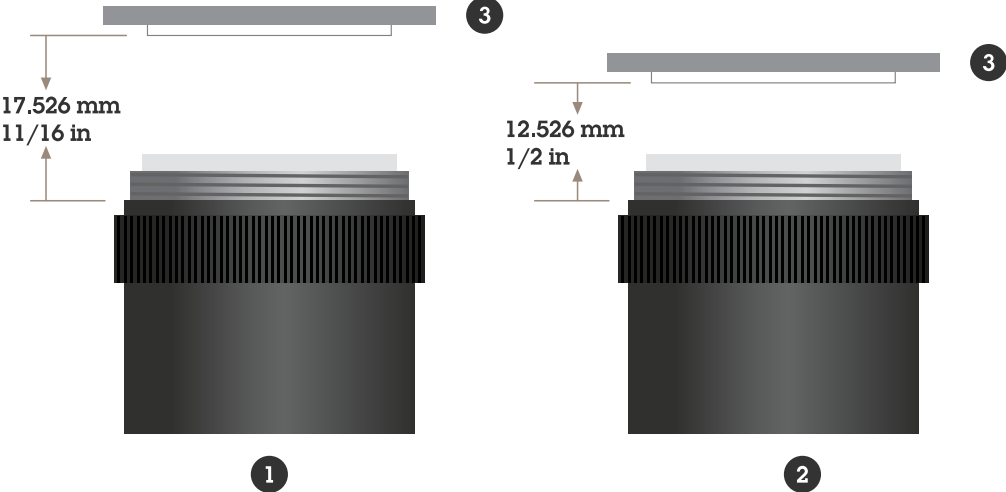

The only difference between a C-mount lens and a CS-mount lens is the flange focal distance (FFD).

- 1 C-mount lens
- 2 CS-mount lens
- 3 Image sensor of the camera

11 Lens marking

A lens's focal length, f-number, and other main features are usually clearly marked on the lens. This is an example.

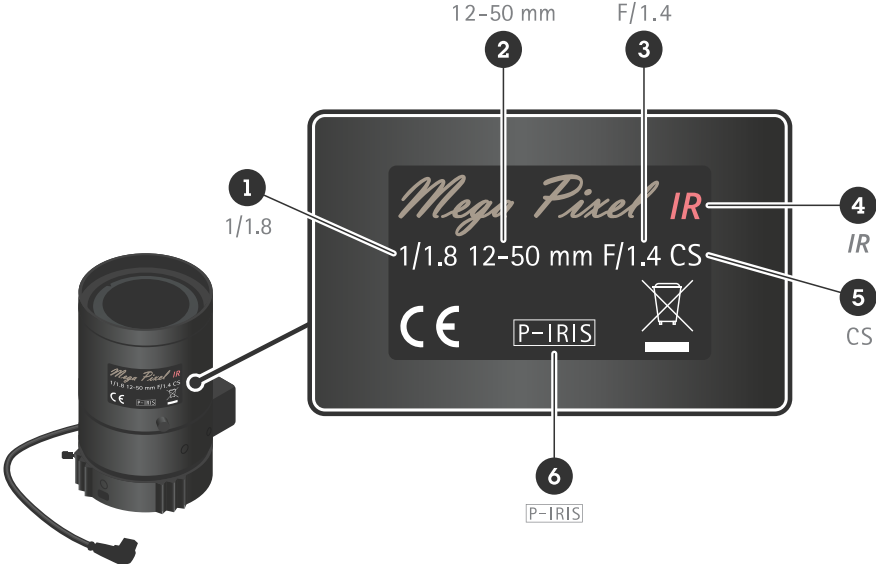

- 1 Sensor format: 1/1.8
- 2 Focal length: 12-50 mm

- 3 *F-number: F/1.4*
- 4 *Lens mount type: CS-mount*
- 5 *IR compensated lens*
- 6 *Iris type: P-Iris*

12 Tools

To help you choose when it comes to cameras, lenses, and other accessories Axis provides helpful tools like Lens calculator, AXIS Site Designer, and Accessory selector. They are accessible from www.axis.com/support/tools

12.1 Lens calculator

Our lens calculator tool determines camera coverage and pixel density at defined distances for different camera/lens combinations.

The pixel density previews are example images that indicate the expected image quality. The actual image quality and possibility to recognize or identify a person or object depend on factors such as object motion, video compression, lighting conditions, camera focus, and lens distortion.

The listed pixel density requirements for detect, observe, recognize, and identify in Lens calculator apply when persons view images from visual cameras. Software that analyzes images, such as license plate verification, might require other pixel densities.

 **AXIS P1377** [🔗](#)

 Resolution: 2592x1944  Lens: Lens i-CS 9-50 mm F1.5 8 MP

Distance (m) 1	Pixel density (px/m)	Scene width (m) 2	Scene height (m) 3	Focal length (mm)
26	263.5	9.8	7.3	13.4

Distance Range ▾

Focal length (FoV ~ 22°)

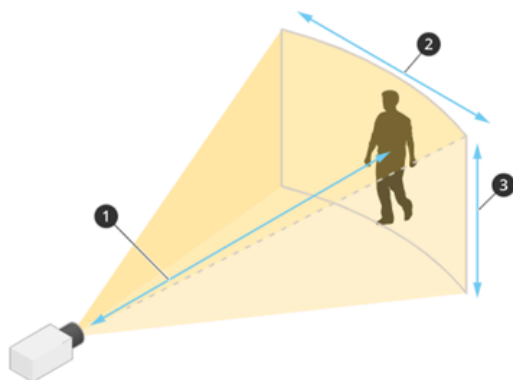

Requirement	px/m	Fulfilled
Detect	25	✓
Observe	63	✓
Recognize	125	✓
Identify	250	✓



Screenshot of the lens calculator tool.

12.2 AXIS Site Designer

Use AXIS Site Designer to streamline surveillance system design through installation workflows. Whether you need to create a system with thousands of Axis devices or just a few, AXIS Site Designer lets you design, approve, and install surveillance systems that fit your exact operational requirements and needs. Intuitive product selectors make it easy to identify the ideal cameras and devices for each situation and

choose the mounts and accessories to match them and their placement. System storage and bandwidth can also be effectively estimated.

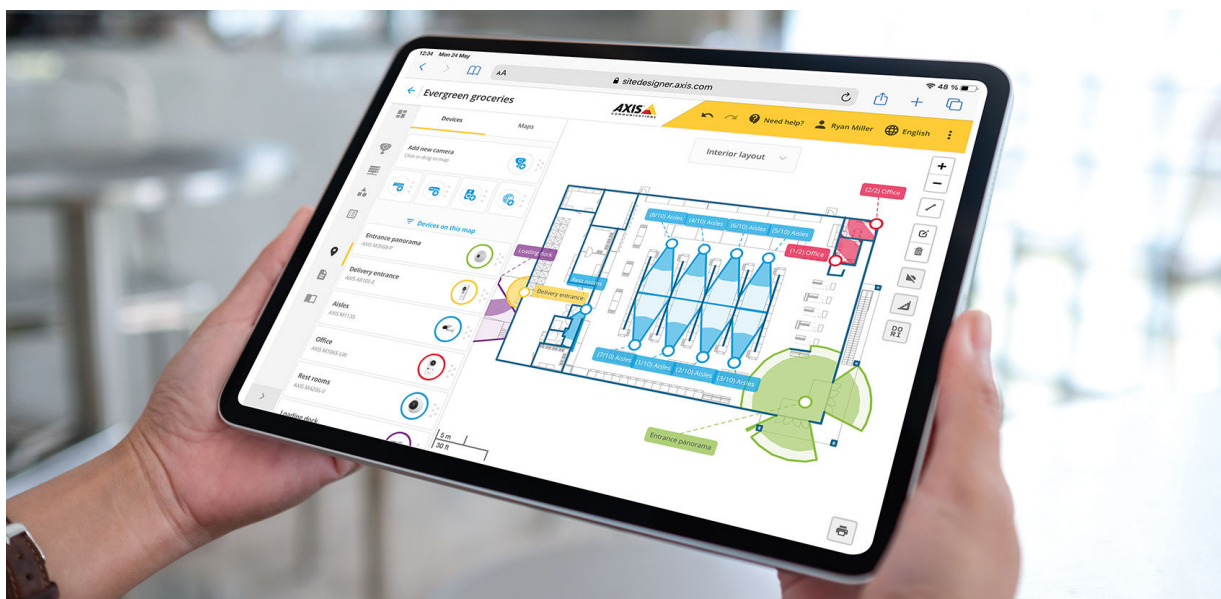

12.3 Accessory selector

This tool helps you pick the right accessories such as lens, mount, housing, bracket, and power supply for your cameras.

About Axis Communications

Axis enables a smarter and safer world by creating solutions for improving security and business performance. As a network technology company and industry leader, Axis offers solutions in video surveillance, access control, intercom, and audio systems. They are enhanced by intelligent analytics applications and supported by high-quality training.

Axis has around 4,000 dedicated employees in over 50 countries and collaborates with technology and system integration partners worldwide to deliver customer solutions. Axis was founded in 1984, and the headquarters are in Lund, Sweden